

Manzel[®]

Pumping Packages

LUBRIQUIP[®]
Lubrication & Dispensing Solutions

FORCE FEED BOX LUBRICATOR = true modularity

Wide choice of standard modular components helps you meet application requirements more exactly without the added costs of a custom system.

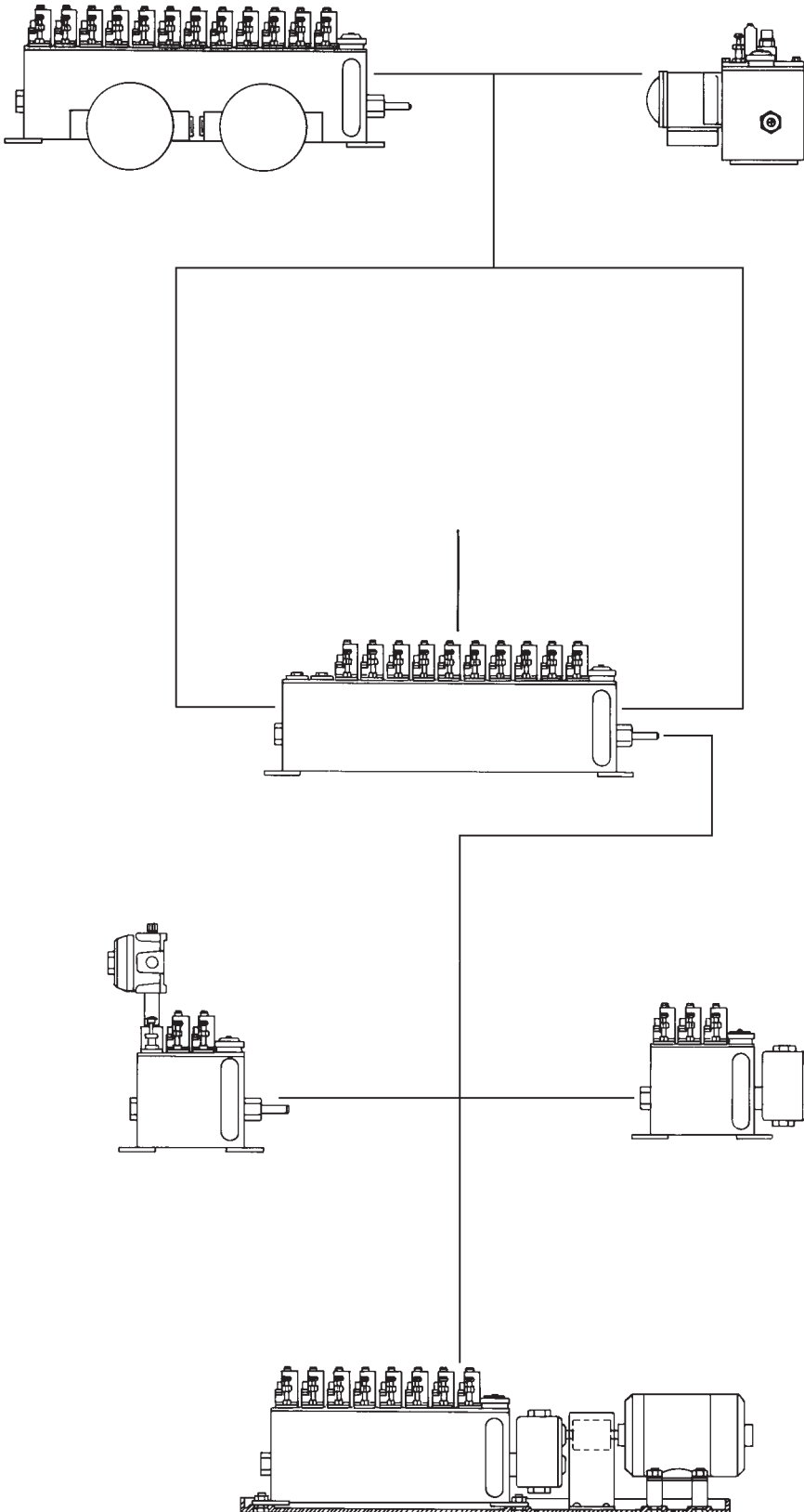

RESERVOIR ACCESSORIES:

Automatic fill, low level, and electric and steam heater options. For details see page 12 thru 15.

PUMPS:

Two pump styles are available for use in the Manzel Model MBL Box Lubricator. The first is the Model 88 Pump (reference literature 51025), which is ideal for light - medium duty applications. The model 88 pump is interchangeable with pumps from competitive lubricators. The second offering is the Model 76 Pump (reference literature 51021), which is ideal for heavy-duty applications. Both styles of pump provide pressures up to 7,500 PSI for mineral or synthetic oils. See complete details in reference literature.

RESERVOIRS:

Eight reservoir capacities are available to hold from 4 to 40 pints and accommodate from 1 to 24 pumps. Blank cover assemblies are available for unused pump stations. For details see pages 4 and 5.

SHAFT ROTATION ALARMS:

Three shaft rotation alarm options are available. These options use one pump station on the reservoir and are available with SPDT or DPDT switches or without a switch. For details see page 14

DRIVE OPTIONS:

Eighteen drive options are available from direct drive to a reduction ratio of 400:1. Options provide left- or right-hand end of reservoir mounting, end or rear rotary drives, end ratchet drives and gear reducers. For details see pages 8, 9, and 10.

MOTOR AND MOTOR MOUNTING BASE OPTIONS:

Single- and three-phase motors are available at ratings of 1/3, 1/4 and 1/2 hp, for 115/230 volt or 230/460 volt, an explosion-proof, TEFC or TENV configuration. Some motor configurations are available foot-mounted and/or face-mounted.

Eight sizes of motor mounting bases are available to accommodate the various reservoir sizes. For details see page 11.

INTRODUCTION

MODULARITY

Force Feed Box Lubricators provide true modularity that permits customizing a pump-to-point lubrication system from off-shelf components. The modular variables are shown on page 2 and consist of the following categories of components:

- Pumps
- Reservoir
- Reservoir Heaters
- Reservoir Oil Level Controls
- Drives
- Shaft Rotation Alarm
- Motor and Motor Mounting Bases

In addition to these Force Feed Box Lubricator components, Lubriquip offers a complete line of auxiliary equipment. Also, Manzel pumping packages can be used with divider valves in a series progressive installation. Lubriquip's performance-proven products that may be used with Modular Box Lubricators are listed below along with the respective literature number.

- Lube Line Alert 54000
- Lube Sentry 15831
- Lube Sentinel II Monitor 14701
- Lube Meter Panel 44630
- Check Valves 15825
- In-Line Filters 15200
- MH Modular Divider Valves 10103

DESCRIPTION

A basic pump-to-point system is shown in the illustration which depicts six pumps mounted on a common reservoir from which each pump is dispensing oil to a single lubrication point. These pumps are operated by individual cams on the drive shaft.

PUMP-TO-POINT SYSTEM

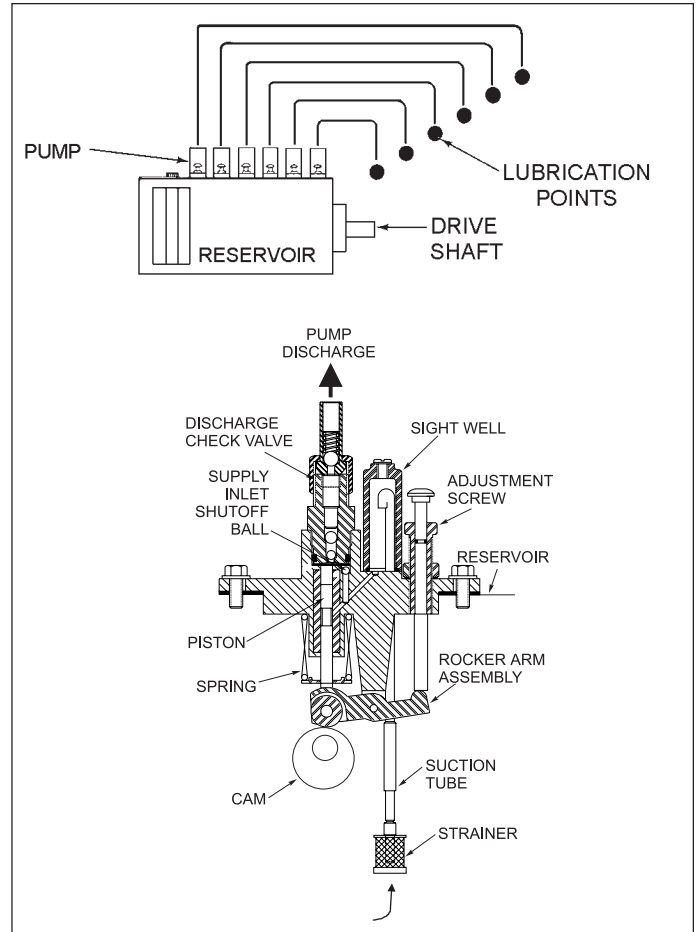

FEATURES/BENEFITS

- Force Feed Box Lubricators provide a proven, cost-effective way to assemble customized oil systems that meet specific requirements by using standard modular components.
- Force Feed Box Lubricators increase opportunities to standardize lube system components and reduce lube maintenance and service costs.
- Force Feed Box Lubricators save you system design dollars and lead time.
- Force Feed Box Lubricators are dependable and backed by the industry's most comprehensive international distributor network — with application expertise, parts stocks and factory-trained service nearby, wherever you are located.

INTERCHANGEABILITY, CONVERSION AND RETROFITS

Lubriquip Model 88 Pumps have been designed to be easily interchangeable with other manufacturers' pumps. For details contact your local Lubriquip representative or call on us for system design and application assistance. At the factory and in the field through our network of distributors, we have unmatched experience in the design and effective application of lubrication systems. We also have in-depth know-how in the application of these systems in your specific industry.

APPLICATIONS AND INDUSTRIES

All working parts of the Force Feed Systems are totally enclosed away from dirt, water and impurities. And, each moving part is self-lubricated at all times by the fluid in the reservoir. This and the wide range of options, high discharge pressure and rugged construction plus the many other features and benefits make Force Feed Systems ideally suited for these applications and industries:

APPLICATION	INDUSTRY	USE
Compressors	Petrochemical Refineries, Gas Transmission, Injection and Storage Cold Storage General Manufacturing Air Systems	Lubricate cylinder walls and piston shaft packing.
Edgers, Planers Band Saws	Lumber	Lubricate slides and ways. Blade coolant (see note).
NOTE Using lubricant as a coolant permits burning saw dust without drying.		
Mixers	Rubber	Used in the blending process and to lubricate dust stop seals.
Can Lid Presses	Food Processing	Lubricate high-speed bearings.
Band Saws	Lumber	Saw guides.

RESERVOIRS

DESCRIPTION

Eight reservoir styles are available for the Model 76/88 Pump. Each is ruggedly built to reduce deflection and provide longer life. The end plates supporting the shaft main bearings are heavy gage steel welded to the main body.

Camshaft intermediate support bearings are bottom mounted to an inside channel to provide maximum rigidity without adding length.

Each reservoir is equipped to handle the maximum number of pumps. Unused pump stations are covered with a gasket, blank cover assembly that can easily be removed to convert to an active pump station.

Additional pump stations are required for the following options:

- Automatic Fill Options FI and F2
- Low Level Option L1
- Shaft Rotation and Low Level Alarm Options (S1, S2 and S3)

FEATURES/BENEFITS

- Rugged construction for durability
- Complete assembly - includes level sight gauge, fill cup and drain plug
- Versatile - permits mounting drive motor on right or left end
- Precise camshaft alignment insures proper lubrication by all pumps

SPECIFICATIONS

ORDERING CODE	TANK CAPACITY PINTS	MAXIMUM PUMP STATIONS
T1	4	2
T2	6	3
T3	8	5
T4	12	8
T5	16	12
T6	24	16
T7	32	20
T8	40	24

DIMENSIONS

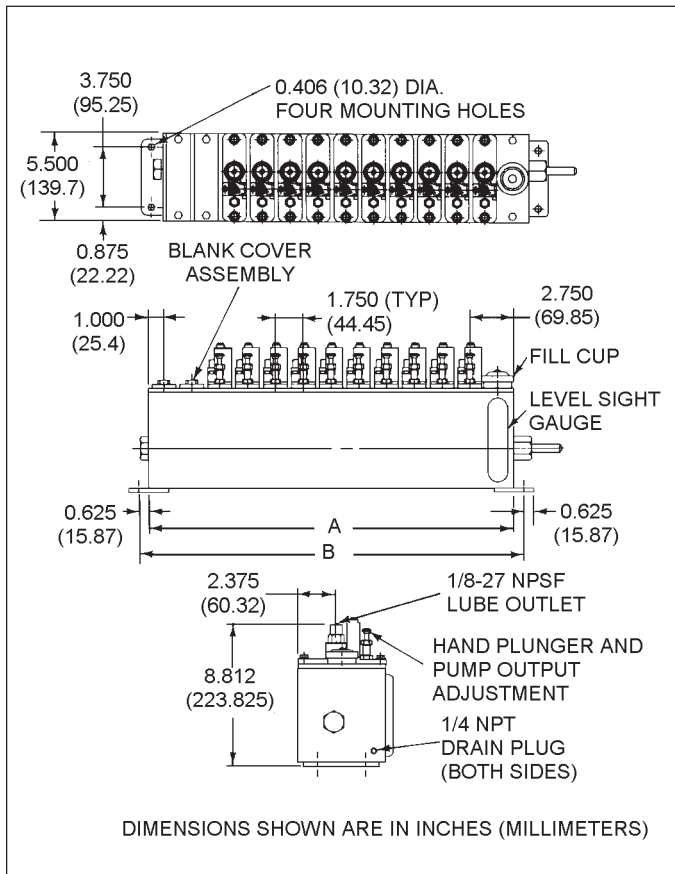

OPTION	SIZE		DIMENSIONS - INCHES (MILLIMETERS)			
	PINTS	LITERS	A		B	
T1	4	1.89	5.500	(139.70)	6.750	(171.45)
T2	6	2.84	7.250	(184.15)	8.500	(215.90)
T3	8	3.79	10.750	(273.05)	12.000	(304.80)
T4	12	5.68	16.000	(406.40)	17.250	(438.15)
T5	16	7.57	23.000	(584.20)	24.250	(615.95)
T6	24	11.36	30.000	(762.00)	31.250	(793.75)
T7	32	15.14	37.000	(939.80)	38.250	(971.55)
T8	40	18.93	44.000	(1,117.60)	45.250	(1,149.35)

NOTE

A blank cover assembly will be provided for all unused pump stations.

ORDERING INFORMATION

Replacement reservoirs are available only with drives. Order reservoir and drive option from menu. Omit all other options when ordering.

PUMPS

DESCRIPTION

Force Feed Box Lubricators are heavy-duty precision metering pumps capable of accurately pumping small flows of either mineral or synthetic oil to machinery injection points. The single-piston pump is mechanically driven from a common camshaft in the reservoir and are adjustable from 1 to 27 drops per stroke. The drive options, shown on page 8 thru 10, provide many more variations to suit the application. Model 76/88 Pumps are interchangeable with competitive models. The pump's maximum pressure is variable up to 7,500 psi depending on the piston size. All working parts are totally enclosed away from dirt, water, and impurities and self-lubricated at all times by the fluid in the reservoir.

Model 76/88 Pumps are rugged, heavy duty units. The pump cylinder housing is a precision machined casting fitted with an alloy steel piston.

The pump is actuated by a hardened steel roller following a cam for low torque and longer life. The visual sight is one-piece injection molded material that is impervious to ultra-violet rays, and mineral and synthetic oils.

Three piston sizes are available to produce outputs up to 27 drops per stroke.

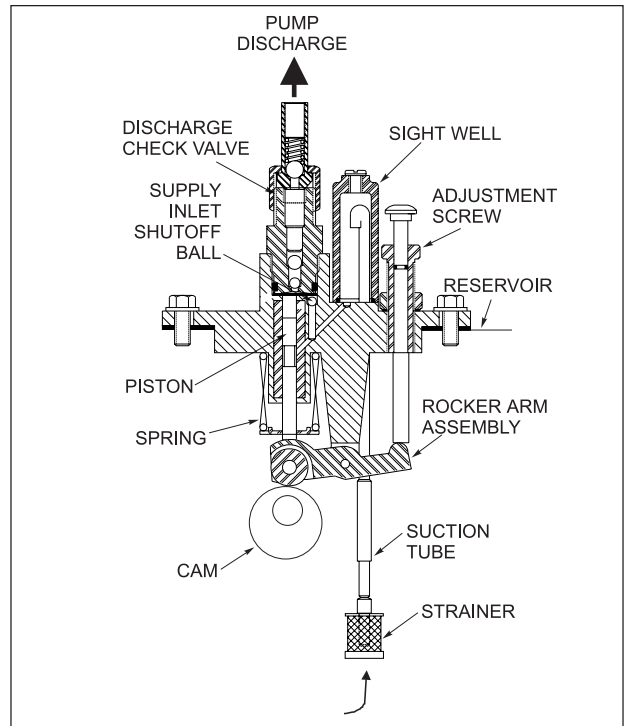
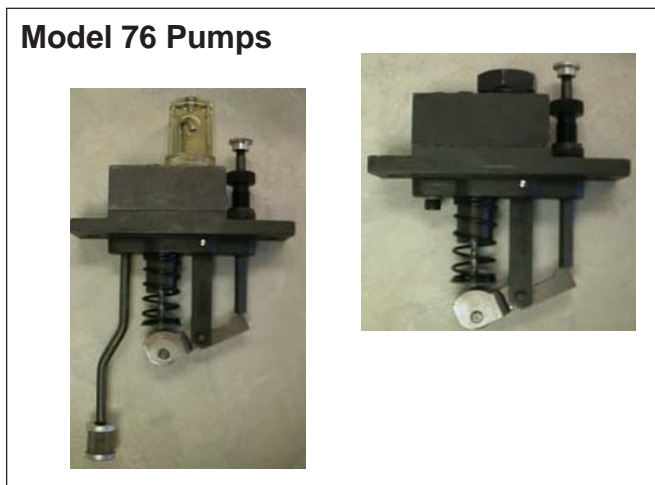
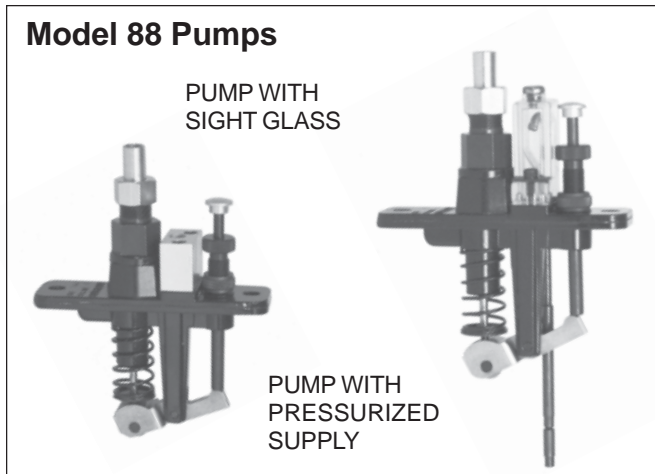

Pumps With Sight Glass

FEATURES/BENEFITS

- Rugged construction for high performance and durability
- Easy serviceability - pumps can be added or replaced quickly
- Pump output is easily adjustable

OPERATION

Pumps With Sight Glass

Rotation of the lubricator cam actuates the pump rocker arm assembly to operate the pump piston. On the piston down-stroke, spring pressure is exerted on the piston causing it to follow the cam. As it moves down, a pressure reduction is created between the piston and the check valve and the valve closes. The supply inlet shut-off ball is then unseated and lubricant is drawn into the piston cylinder from the sight well. This creates a pressure reduction (vacuum) in the airtight sight well that causes lubricant from the reservoir to be drawn into the well until pressure is equalized. On the

piston up-stroke, the oil in the cylinder is injected out through the discharge check valve to the machine injection point.

The number of drops seen falling in the sight well is the amount of oil discharged by the pump. Each pump can be adjusted by means of an external screw. This changes the length of the pump stroke which changes the pump discharge volume.

Pumps With Pressurized Supplies

Rotation of the lubricator cam actuates the pump rocker arm assembly to operate the pump piston. On the piston down-stroke, spring pressure is exerted on the piston causing it to follow the cam. As it moves down, a pressure reduction (vacuum) is created between the piston and the discharge check valve and the valve closes. This allows the pressurized supply to unseat the supply inlet shut-off ball and pressurize the piston bore with lubricant. On the piston up-stroke, the piston forces the supply inlet shut-off ball to seat and shut off the pressurized supply. Lubricant in the piston cylinder is forced out through the discharge check valve to the machine injection point. Each pump can be adjusted by means of an external screw. This changes the length of the pump stroke which changes the pump discharge volume.

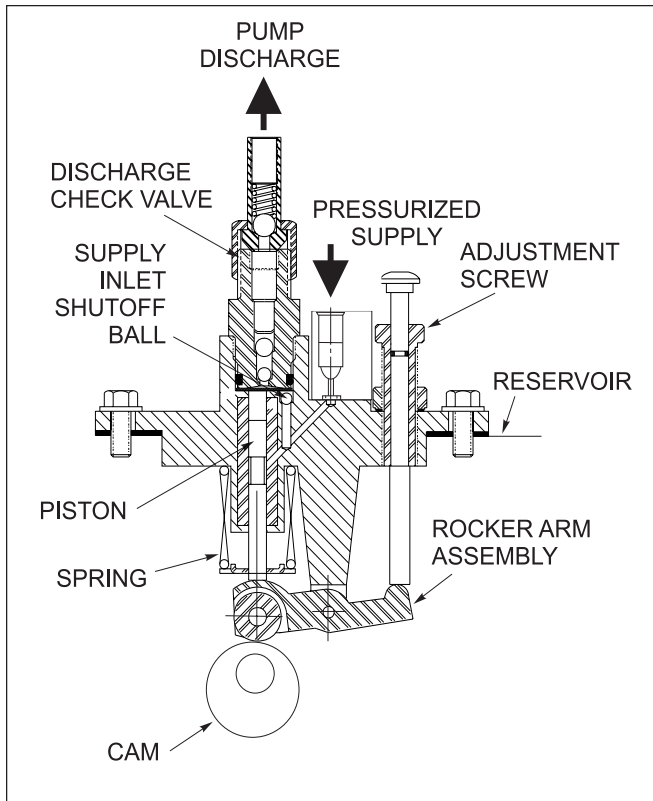

Pumps With Pressurized Supplies

ADJUSTMENT

Pump discharge (output flow) can be adjusted within the min.\max. ranges as shown in the illustration. The adjustment is linear. Therefore, positioning the screw midway will produce one-half of the pump capacity. To adjust the flow, proceed as follows:

1. Loosen adjusting screw locknut.
2. Turn the adjusting screw to the desired position and, with the pump operating, count the drops falling in the sight well for a one-minute interval.
3. Tighten adjusting screw locknut.

Calculate Pints Per Day As Follows:

$$\frac{\text{Number of Drops/Min.} \times 1440 \text{ (Minutes in a Day)}}{14115 \text{ (Number of drops in a Pint)}} = \text{Pints/Day}$$

Calculate Minimum or Maximum Pump Output Capacity

$$\frac{\text{Input Speed} \times \text{Pump Output} \times 1440}{\text{Gear Ratio} \times \text{(Min. or Max. drops/stroke)} \times \text{(Min./day)}} = \text{Min. or Max. Pump Output (Pints Per Day)}$$

14115 (Number of Drops in a Pint)

* Minimum and Maximum Drops Per Stroke Listed in Specifications on the next page.

NOTE: For proper sizing select the appropriate Lubricator brand. Brand as well as piston size will effect minimum and maximum pump capacity.

The following example is a Manzel lubricator, electric motor driven, 300:1 internal ratio, 1/4" pump model 76/88. Solve for maximum flow:

$$\frac{1725 \text{ Motor Speed} \times \text{Max. 12 drops} \times 1440 \text{ Min.}}{300:1 \text{ Gear Ratio} \times \text{per stroke}} = \text{Max. 7.04 Pints/day}$$

14115 (Number of Drops in a Pint)

To Calculate Minimum: Replace the maximum 12 drops per stroke with the minimum 2 drops per stroke:
(1.17 minimum pints per day)

ORDERING INFORMATION

Use the following part numbers if you are ordering only a pump assembly and a Modular Box Lubricator. Blank cover assemblies may be ordered by specifying part number **471-690-054**.

PUMP SPECIFICATIONS										
ORDERING CODE	PISTON SIZE (INCHES)	MAXIMUM PRESSURE (PSI)	*DROPS PER STROKE		CUBIC INCHES PER STROKE		CUBIC CENTIMETERS PER STROKE		STROKES PER MINUTE	
			MAX.	MIN.	MAX.	MIN.	MAX.	MIN.	MAX.	MIN.
76/88B	3/16	7500 PSI	6	1	0.013	0.002	0.213	0.033	50	3
76/88C	1/4	6000 PSI	12	2	0.024	0.004	0.393	0.066	50	3
76/88E	3/8	2500 PSI	27	4	0.055	0.008	0.901	0.131	50	3

*when approaching maximum outputs some oils will stream rather than form drops in sight glass.

- 1 Based on 500 SUS oil at 70°F ambient. Heavier oil will produce fewer but larger drops.
- 2 When approaching maximum outputs, some oils will stream rather than form drops in sight glass.
- 3 For operating pressures over 50% of the rated maximum, consult the factory.

MODEL NUMBER	PUMP SIZE	PART NUMBERS	
		STANDARD PUMP	PRESSURIZED PUMP
76B	3/16 - inch	376-000-000	376-000-120
76C	1/4 - inch	376-000-010	376-000-130
76E	3/8 - inch	376-000-030	376-000-150
88B	3/16 - inch	376-000-001	376-000-121
88C	1/4 - inch	376-000-011	376-000-131
88E	3/8 - inch	376-000-031	376-000-151

PUMP SIGHT GLASS REPAIR KITS

Sight Glass Repair Kits are available for both the Manzel Model 76 & 88 Pumps. Sight Glass Kits are independent of pump sizes

PUMP	SIGHT GLASS KIT
Model 76	562-000-200
Model 88	560-001-860

DRIVES/MOTORS

DESCRIPTION

Six drive configurations, some with several variations, provide a total of 18 options. These configurations are listed below in conjunction with pertinent technical data and a detailed dimensional drawing. All options are available as left- or right-hand.

DIRECT END ROTARY — OPTION G01

This option is shown in the right-hand location. It is not available with the motor option.

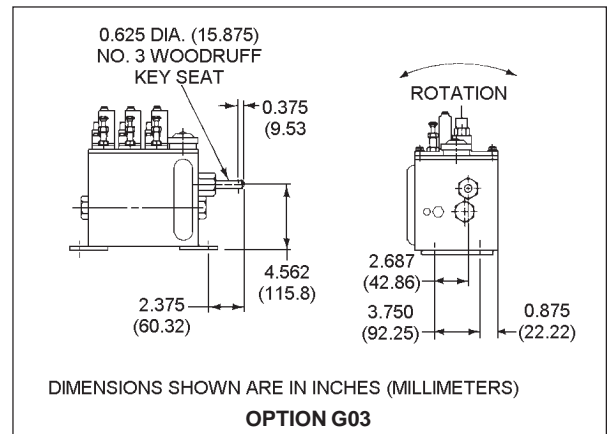
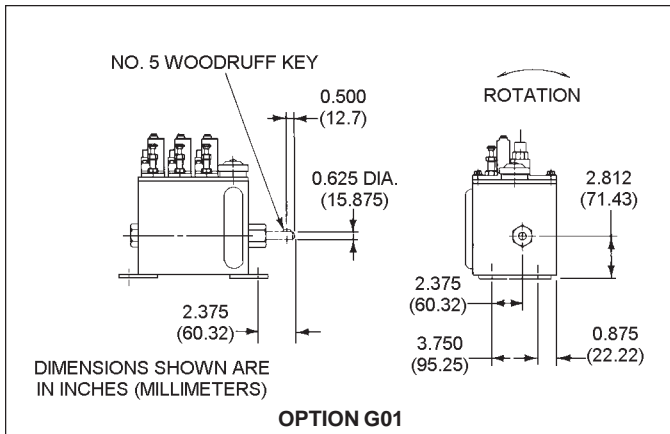

END RATCHET — OPTION G02

Option G02 is shown in the right-hand location. It is not available with the motor option. The drive arm is not included with this option. If desired, specify part number **453-004-603**.

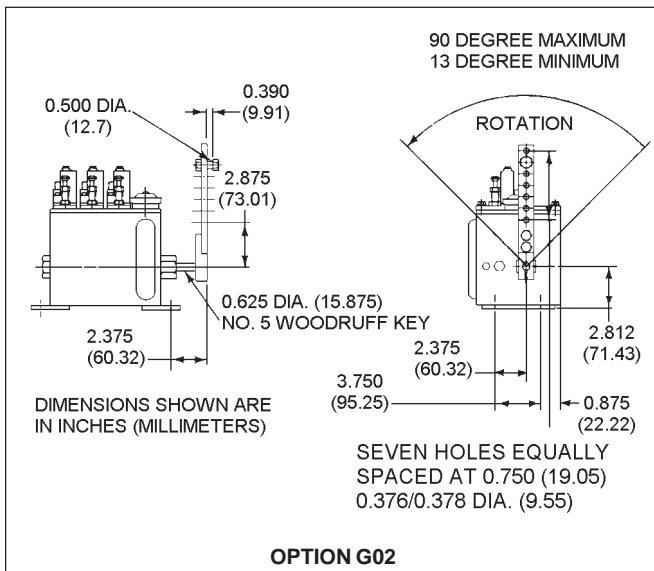

DOUBLE REDUCTION END ROTARY — OPTIONS G05 THROUGH G09

These drive options are available in either left- or right-hand configurations: the right-hand is shown. When the motor option is selected, it is available only for a right-hand drive. It is available in five ratios as follows:

OPTION	RATIO	PART NUMBER
G05	25:1	481-760-012
G06	50:1	481-760-009
G07	100:1	481-760-010
G08	200:1	481-760-011
G09	400:1	481-760-004

END ROTARY RATCHET — OPTIONS G03 AND G04

Option G03 as a right-hand drive is shown. It is not available with the motor option. Specifications are as follows:

OPTION	RATIO	MAXIMUM INPUT SPEED
G03	37-1/2:1	800 rpm
G04	75:1	800 rpm

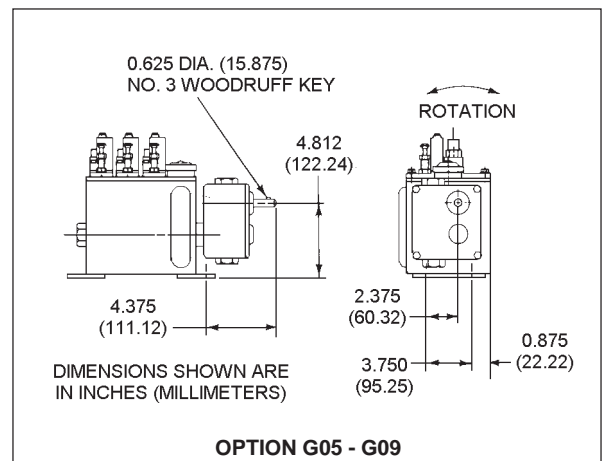

RIGHT ANGLE ROTARY DRIVE — OPTIONS G10 THROUGH G13

These drive options are available for right-hand and left hand drives only. This option is not available with the motor option. Ratios for each drive option are listed below:

NOTE

Top, bottom and front drive locations are available on request as special orders.

OPTION	RATIO
G10	25:1
G11	50:1
G12	188:1
G13	375:1

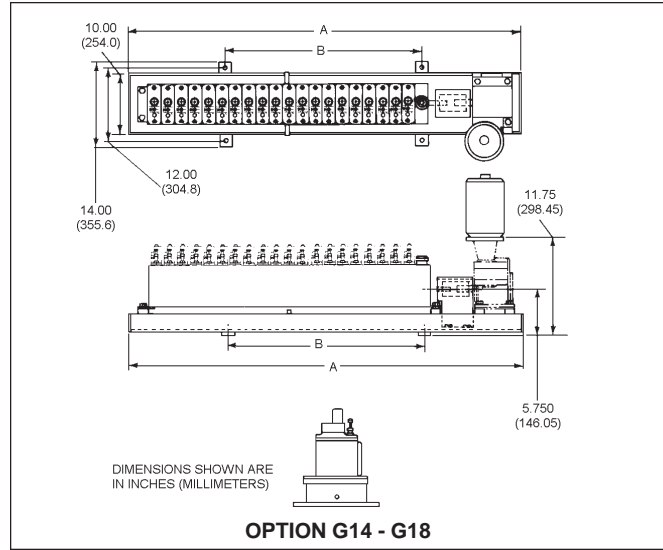

DRIVE LOCATIONS

All drives may be ordered for either right- or left-hand locations, except for Options G05 through G09, when ordered with one of the motor options. When other drive locations are needed, contact Lubriquip or one of its Manzel distributor locations.

MOTORS

Ten motor options are available to meet the following requirements: Other motors may be supplied as specials to meet duty conditions not listed (contact factory).

OPTION	POWER	HORSE VOLTAGE	PHASE	DUTY TYPE	PART NUMBER
M2	1/4	115/230	1	See A	492-440-190
M3	1/4	115/230	1	See B	492-600-090
M5	1/4	230/460	3	See A	492-440-360
M6	1/3	230/460	3	See B	492-600-020
M7	1/2	115/230	1	See C	492-620-060
M8	1/2	230/460	3	See C	492-620-070
M9	1/4	115/230	1	See B	492-600-090
M10	1/2	230/460	3	See B	492-540-310
M11	1/2	115/230	1	See D	492-380-040
M12	1/2	230/460	3	See D	492-380-030

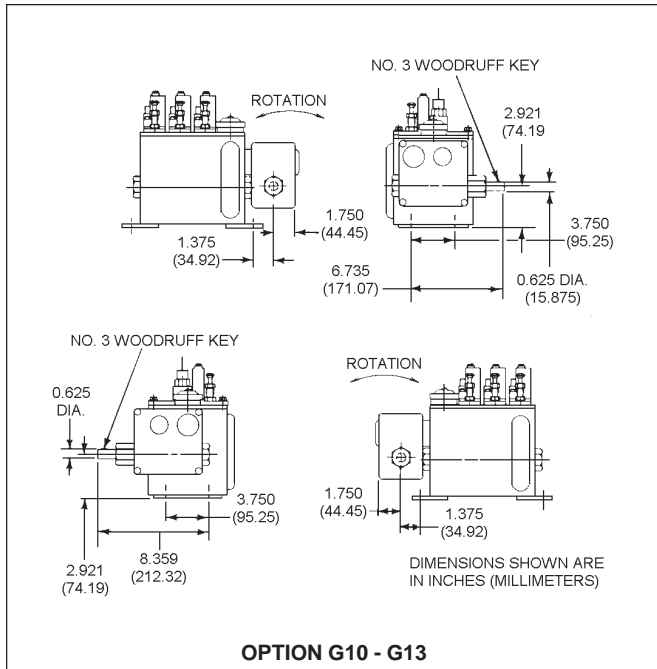

GEAR REDUCER — OPTIONS G14 THROUGH G18

These options are shown below and the ratios and part numbers for each option are as follows:

OPTION	RATIO
G14	100:1
G15	150:1
G16	200:1
G17	300:1
G18	400:1

NOTE

- All motors operate at 1725 rpm
- M2, M3, M5, and M6 are foot-mounted (56F). M7 and M8 are foot-mounted (56F) for T1 through T5 and face-mounted (56C) for T6, T7, and T8. M9 through M12 are face-mounted (56C)

Duty Type:

- A - Totally-enclosed, non-ventilated (TENV)
- B - Hazardous Area, Class 1, Group D
- C - Hazardous Area, severe duty, Class 1, Group C, tropical insulation
- D - Totally-enclosed, fan-cooled (TEFC)

**MOTOR MOUNTING BASES —
OPTIONS P1 THROUGH P5**

A motor mounting base option is available for all standard size reservoirs (Options T1 through T5). These options may be used only with drive options G06 through G09. Dimensional data for the bases is provided below:

DIMENSIONS

OPTION	RESERVOIR CAPACITY	DIMENSIONS (INCHES)			NUMBER OF MOUNTING HOLES
		A	B	C	
P1	4 pints - T1 (1.89 liters)	24.500 (622.30)	20.500 (520.70)	—	4
P2	6 pints - T2 (2.84 liters)	26.250 (666.75)	22.250 (565.15)	—	4
P3	8 pints - T3 (3.79 liters)	29.750 (755.65)	25.760 (654.05)	—	4
P4	2 pints - T4 (5.68 liters)	35.000 (889.00)	15.500 (393.70)	15.500 (393.70)	6
P5	6 pints - T5 (7.51 liters)	42.000 (1066.80)	19.000 (482.60)	19.000 (482.60)	6

NOTE

Millimeter dimensions appear in parentheses below the dimensions given in inches.

**MOTOR MOUNTING BASES —
OPTIONS P6, P7, AND P8**

A motor mounting base option is available for all standard size reservoirs (Options T6, T7, and T8). These options may be used only with drive options G14 through G18. Dimensional data for the bases is shown below:

OPTION	RESERVOIR CAPACITY	DIMENSIONS (INCHES)		NUMBER OF MOUNTING HOLES
		A	B	
P6	24 pints - T6 (11.36 liters)	46.000 (1168.40)	16.000 (406.40)	4
P7	32 pints - T7 (15.14 liters)	53.000 (1346.20)	23.000 (584.20)	4
P8	40 pints - T8 (18.93 liters)	60.000 (1524.00)	30.000 (762.00)	4

NOTE

Millimeter dimensions appear in parentheses below the dimensions given in inches.

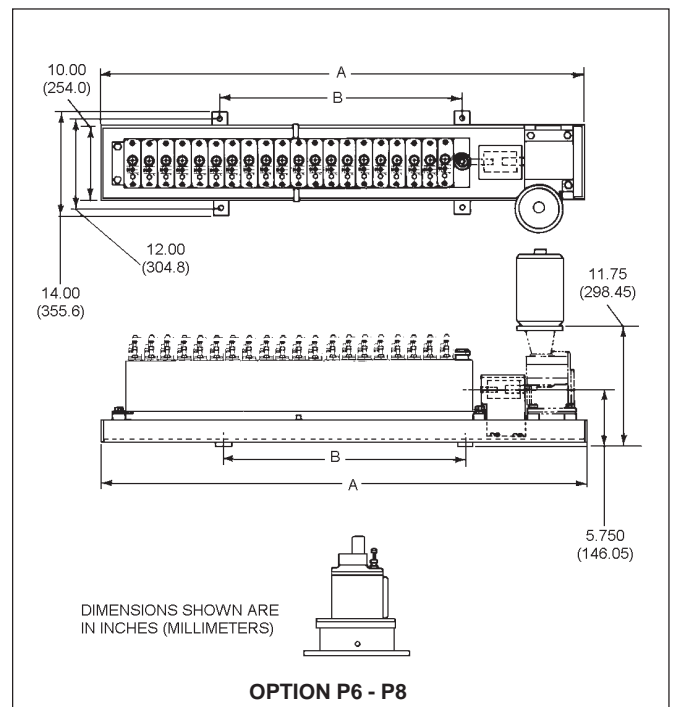
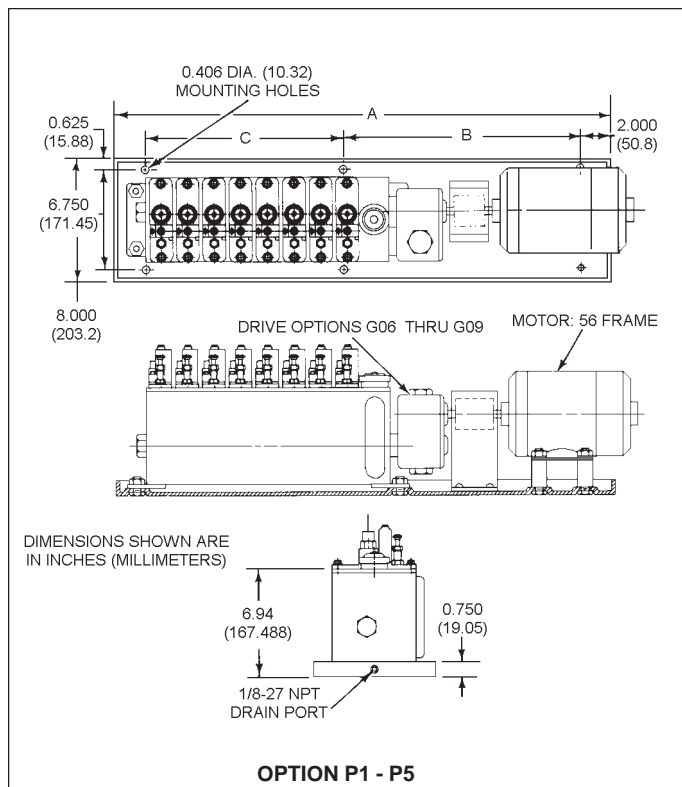

ACCESSORIES

AUTOMATIC FILL — OPTIONS F1, F2, F3, AND F4

OPTION F1 — Gravity Supply

This option is mounted in the last pump station at the end opposite the drive. The only exception is when either a shaft rotation alarm or one of the low level options is specified. Then this option is mounted in the second to the last pump station. Pertinent dimensional data is provided in the following illustration. Specify part number **456-030-031** when ordering this option separately.

NOTE

An inlet oil pressure head of 2 to 5 feet is required for the gravity supply.

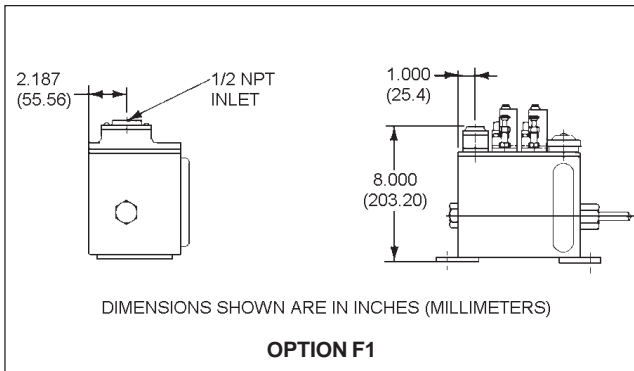

OPTION F2 — Pressurized Supply

This option is mounted in the last pump station at the end opposite the drive. The only exception is when either a shaft rotation alarm or one of the low level options is specified. Then this option is mounted in the second to the last pump station. Pertinent dimensional data is provided in the following illustration. The inlet pressure should be between 15 and 70 psig. Specify part number **456-030-035** when ordering this option separately.

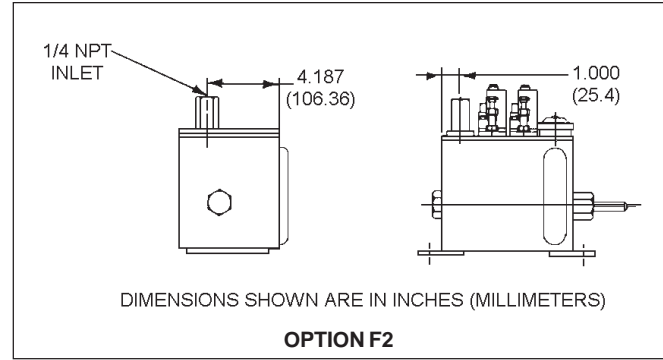

OPTION F3 — Oil Level Controller

This automatic fill option does not require a pump station for mounting. It is mounted only on the front of the reservoir and requires a maximum inlet pressure of 5 psi. Specify part number **456-030-032** when ordering this option separately.

OPTION	RESERVOIR		DIMENSION A	
	PINTS	LITERS	INCHES	MILLIMETERS
T1	4	1.89	1.00	25.40
T2	6	2.84	2.75	69.85
T3	8	3.79	3.63	92.08
T4	12	5.68	3.63	92.08
T5	16	7.57	11.50	292.10
T6	24	11.36	15.00	381.00
T7	32	15.14	12.38	314.33
T8	40	18.93	14.13	358.78

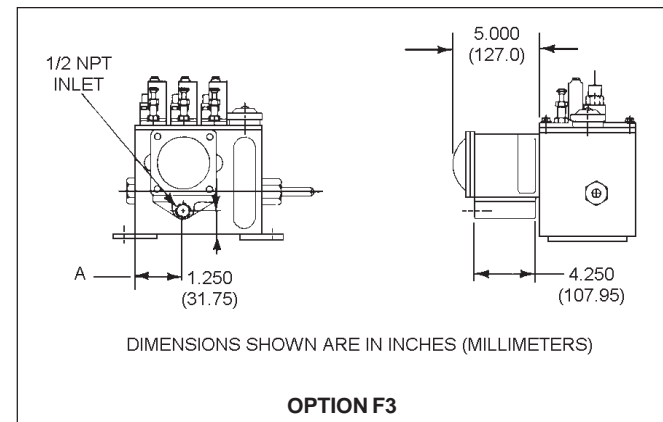

OPTION F4 — Pressurized Supply With Level Control

This automatic fill option mounts on the front of the reservoir and requires a 0 to 70 psi inlet supply. The switch actuates when a 1/2 to 3/4 loss of oil level occurs in the controller.

ELECTRICAL DATA:

- Contacts: Single-Pole, Double-Throw
- Contact Rating: 15 amps at 115/230 or 480 VAC
- 0.5 amps at 125 VDC
- 0.25 amps at 250 VDC
- Switch Rating: Class 1, Groups C and D, Division I

OPTION	RESERVOIR		DIMENSION A	
	PINTS	LITERS	INCHES	MILLIMETERS
T1	4	1.89	1.00	25.40
T2	6	2.84	2.75	69.85
T3	8	3.79	3.63	92.08
T4	12	5.68	3.63	92.08
T5	16	7.57	11.50	292.10
T6	24	11.36	15.00	381.00
T7	32	15.14	12.38	314.33
T8	40	18.93	14.13	358.78

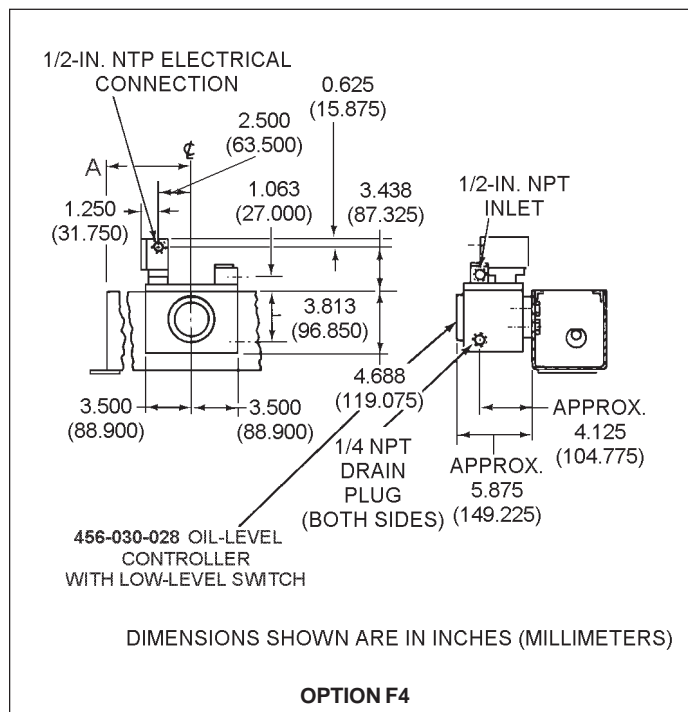

LOW LEVEL SWITCH — OPTION 5 L1, & L2 Option L1 - Class 1, Group C&D

The low level switch is single-pole, double-throw and meets the explosion-proof requirements of Class 1, Groups C and D, as well as Class 2, Groups E, F, and G. This option is mounted in the last pump station opposite the drive end. The only exception is when a shaft rotation alarm option is specified, then it is mounted in the third to the last pump station. Dimensional data and electrical ratings are shown on the following illustration.

Specify part number **456-010-164** when ordering this option separately.

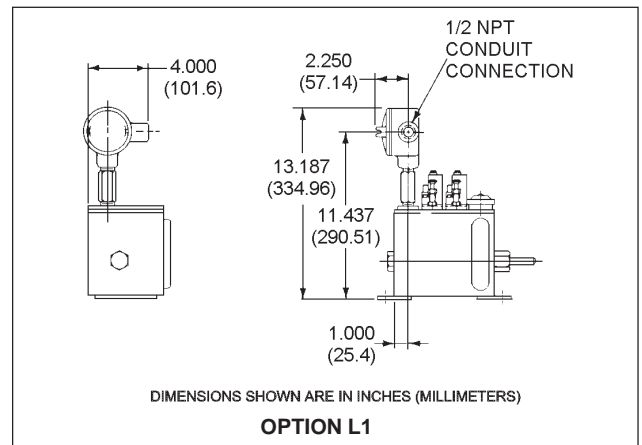

ELECTRICAL RATINGS:

- 15 amps at 115/230 or 480 VAC
- 1/2 amp at 125 VDC
- 1/4 amp at 250 VDC

OPTION L2

The low level switch is single pole-single throw, N.C. Electrical rating is 10 watts @120 VAC (Minimum). This option is mounted in the last pump station opposite the drive end. The only exception is when a shaft rotation alarm option is specified, then it is mounted in the third to the last pump station. Dimensional data and electrical ratings are shown on the following illustration.

Specify part number **456-010-190** when ordering this option separately.

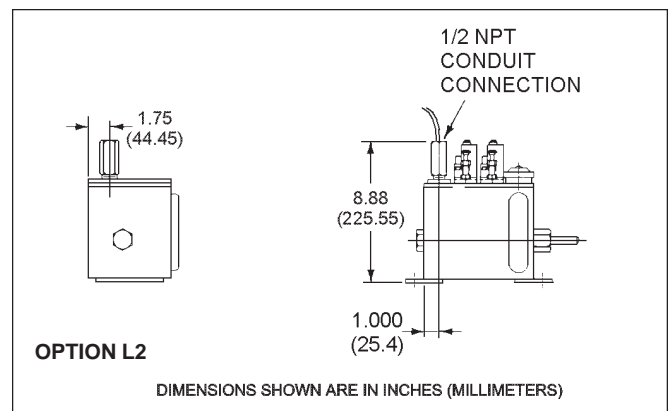

SHAFT ROTATION ALARM — OPTIONS S1, S2, AND S3

The shaft rotation alarm meets the explosion-proof requirements of Class 1, Groups B, C, and D, as well as Class 2, Groups E, F and G. It is always mounted in the last pump station at the end of the reservoir opposite the drive. Option S1 is an alarm without a switch. Options S2 and S3, are single-pole, double-throw and double-pole, double-throw, switches respectively. These switches are factory set to signal when the pressure falls below 50 psig (3.515 kg/cm²). Pressure switch operation is dependent on shaft rotation and adequate oil level to maintain switch setting. Dimensional data and electrical ratings are provided in the illustration shown below.

OPTION	PART NUMBER
S1	301-300-039
S2	456-020-459
S3	456-020-460

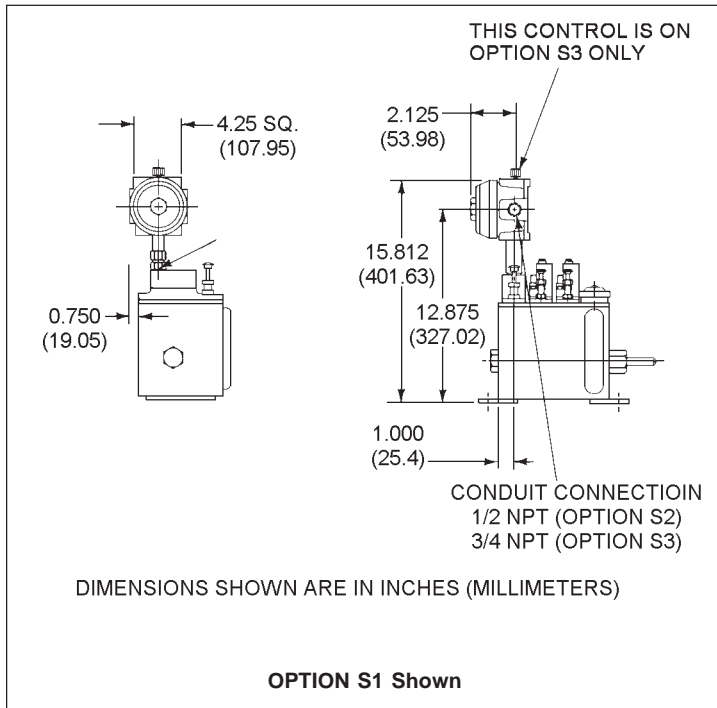

ELECTRICAL RATINGS:

- 15 amps at 125/250 VAC
- 1/2 amp at 125 VDC
- 1/4 amp at 250 VDC

ELECTRIC HEATER — OPTIONS H1 THROUGH H6

Electric heater options are not available for the four-pint reservoir (Option T1). Heater options H2 and H4 require two heaters. Heater options H5 and H6 require three heaters. Specifications for these heaters are provided in the following tables and the dimensional data is shown in the illustrations.

CAUTION

Heater elements must be completely submerged in oil at all times.

Heater Options H1, H2 and H5:

Voltage	115 volts
Wattage	150 watts
Thermostat Voltage	115/230 volts
Temperature Range	-100°F - 500°F (38°C - 260°C)
Watt Density	20 w/sq. in.
Hazardous Area Rating	Class 1, Group D
Part Number	492-041-721

Heater Options H3, H4 and H6:

Voltage	120 volts
Wattage	200 watts
Thermostat Voltage	120 volts
Temperature Range	60° to 240°F (15.6 to 116°C)
Watt Density	22 w/sq.in.
Hazardous Area Rating	Class 1, Group B
Part Number	492-041-734

DIMENSIONS - INCHES (MILLIMETERS)*									
RESERVOIR CAPACITY	OPTIONS H1, H2 AND H5				OPTIONS H3, H4 AND H6				
	A	B	C	D	E	F	G	H	OPTION
6 pints - T2 (2.84 liters)	4.750 (120.65)	3.625 (92.08)	N/A	N/A	4.5 (114.30)	1.875 (47.625)	N/A	N/A	H1 or H3
8 pints - T3 (3.79 liters)	4.125 (104.78)	4.500** (114.30)	N/A	N/A	4.5 (114.30)	5.375 (136.53)	N/A	N/A	H1 or H3
12 pints - T4 (5.68 liters)	4.125 (104.78)	9.750 (247.65)	N/A	N/A	4.5 (114.30)	5.375 (136.53)	N/A	N/A	H1 or H3
16 pints - T5 (7.57 liters)	4.125 (104.78)	6.250 (158.75)	10.50	N/A	4.5 (114.30)	7.125 (180.98)	8.750 (222.25)	N/A	H2 or H4
24 pints - T6 (11.36 liters)	4.125 (104.78)	8.000 (203.20)	14.00	N/A	4.5 (114.30)	8.875 (225.43)	12.25 (311.15)	N/A	H2 or H4
32 pints - T7 (15.14 liters)	4.125 (104.78)	6.250 (158.75)	12.25 (311.15)	12.25 (311.15)	4.5 (114.30)	7.125 (180.98)	10.50 (266.70)	12.25 (311.15)	H5 or H6
40 pints - T8 (18.93 liters)	4.125 (104.78)	6.250 (158.75)	15.75 (400.05)	15.75 (400.05)	4.5 (114.30)	7.125 (180.98)	15.75 (400.05)	14.00 (355.60)	H5 or H6

*All dimensions are for right- or left-hand drive unless otherwise noted.
 **4.500 (114.30) is for right-hand drive. For left-hand drive, Dimension B = 6.250 (158.75).

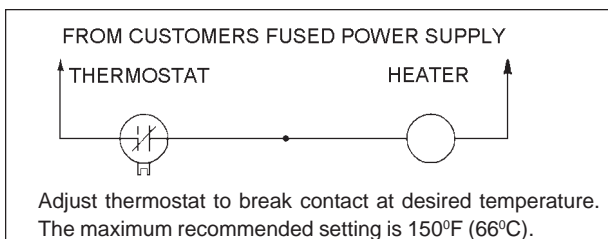
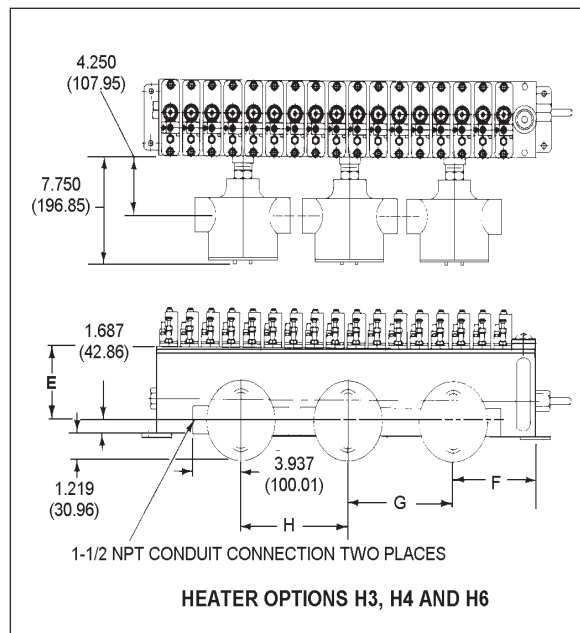
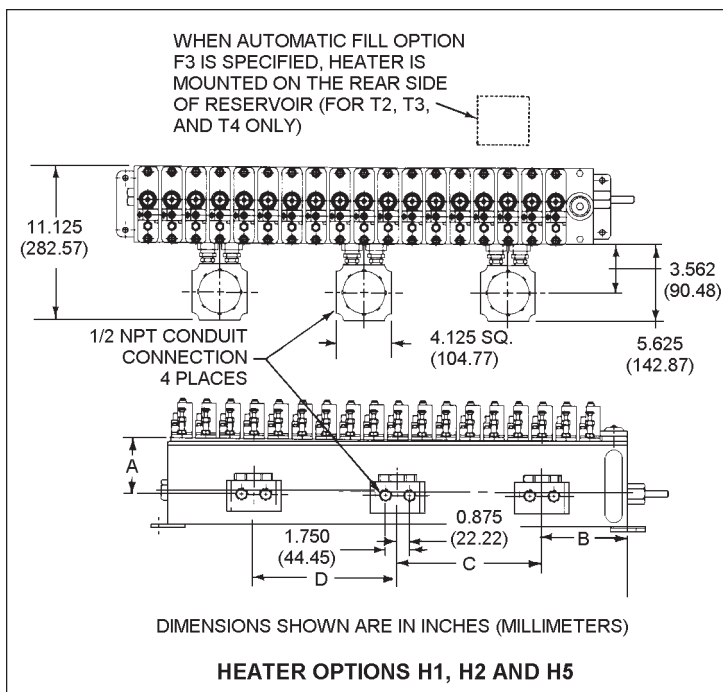

WIRING SCHEMATIC FOR HEATER OPTIONS

PACKAGE ORDERING INFORMATION (MENU)

MBL-XX-XXX XX-XXX X-XX-XX-XX-XX-XX-XX

RESERVOIR SIZE:

- T1 - 4 PINTS, 2 PUMP STATIONS MAX.
- T2 - 6 PINTS, 3 PUMP STATIONS MAX.
- T3 - 8 PINTS, 5 PUMP STATIONS MAX.
- T4 - 12 PINTS, 8 PUMP STATIONS MAX.
- T5 - 16 PINTS, 12 PUMP STATIONS MAX.
- T6 - 24 PINTS, 16 PUMP STATIONS MAX.
- T7 - 32 PINTS, 20 PUMP STATIONS MAX.
- T8 - 40 PINTS, 24 PUMP STATIONS MAX.

*PUMP SIZE:

- 76 / 88B - 3/16 IN. DIA. MODEL 76 & 88 PUMP
 - 76 / 88C - 1/4 IN. DIA. MODEL 76 & 88 PUMP
 - 76 / 88E - 3/8 IN. DIA. MODEL 76 & 88 PUMP
- SEE LITERATURE 51025 FOR 88 PUMP OPTIONS
SEE LITERATURE 51021 FOR 76 PUMP OPTIONS

*PUMP QUANTITY:

- 01 - 1 PUMP
 - THRU
 - 24 - 24 PUMPS
- SEE NOTES 1 AND 2

DRIVE OPTIONS:

- G01 - DIRECT END ROTARY
 - G02 - END RATCHET
 - G03 - END ROTARY RATCHET 37-1/2:1 RATIO
 - G04 - END ROTARY RATCHET 75:1 RATIO
 - G05 - DOUBLE REDUCTION END ROTARY 25:1 RATIO
 - G06 - DOUBLE REDUCTION END ROTARY 50:1 RATIO
 - G07 - DOUBLE REDUCTION END ROTARY 100:1 RATIO
 - G08 - DOUBLE REDUCTION END ROTARY 200:1 RATIO
 - G09 - DOUBLE REDUCTION END ROTARY 400:1 RATIO
 - G10 - RIGHT ANGLE ROTARY 25:1 RATIO
 - G11 - RIGHT ANGLE ROTARY 50:1 RATIO
 - G12 - RIGHT ANGLE ROTARY 188:1 RATIO
 - G13 - RIGHT ANGLE ROTARY 375:1 RATIO
 - G14 - 100:1 RATIO GEAR REDUCER
 - G15 - 150:1 RATIO GEAR REDUCER
 - G16 - 200:1 RATIO GEAR REDUCER
 - G17 - 300:1 RATIO GEAR REDUCER
 - G18 - 400:1 RATIO GEAR REDUCER
- ALL RESERVOIRS
T1 THROUGH T5 RESERVOIRS
T6, T7, AND T8 RESERVOIRS (SEE NOTE 3)

DRIVE LOCATION:

- R - RIGHT-HAND END OF RESERVOIR
- L - LEFT-HAND END OF RESERVOIR

*MOTOR MOUNTING BASE:

- P1 - FOR 4 PINT RESERVOIR
 - P2 - FOR 6 PINT RESERVOIR
 - P3 - FOR 8 PINT RESERVOIR
 - P4 - FOR 12 PINT RESERVOIR
 - P5 - FOR 16 PINT RESERVOIR
 - P6 - FOR 24 PINT RESERVOIR
 - P7 - FOR 32 PINT RESERVOIR
 - P8 - FOR 40 PINT RESERVOIR
- SEE NOTE 4
SEE NOTE 6

*MOTOR OPTION:

- M2 1/4 HP 1725 RPM, 115/230 V,1 PH., TENV MOTOR, FOOT-MOUNTED (56F)
 - M3 1/4 HP 1725 RPM, 115/230 V,1 PH., HAZARDOUS AREA, CLASS 1, GROUP D, FOOT-MOUNTED (56F)
 - M5 1/4 HP 1725 RPM, 230/460 V,3 PH., TENV MOTOR, FOOT-MOUNTED (56F)
 - M6 1/4 HP 1725 RPM, 230/460 V,3 PH., HAZARDOUS AREA, CLASS 1, GROUP D, FOOT-MOUNTED (56F)
 - M7 1/2 HP 1725 RPM, 115/230 V,1 PH., HAZARDOUS AREA, CLASS 1, GROUP C, SEVERE DUTY, TROPICAL INSULATION
 - M8 1/2 HP 1725 RPM, 230/460 V,3 PH., HAZARDOUS AREA, CLASS 1, GROUP C, SEVERE DUTY, TROPICAL INSULATION
 - M9 1/4 HP 1725 RPM, 115/230 V,1 PH., 60HZ, CLASS 1, GROUP D, FACE-MOUNTED (56C)
 - M10 1/2 HP 1725 RPM, 230/460 V,3 PH., 60HZ, CLASS 1, GROUP D, FACE-MOUNTED (56C)
 - M11 1/2 HP 1725 RPM, 115/230 V,1 PH., 60HZ, TEFC, FACE-MOUNTED (56C)
 - M12 1/2 HP 1725 RPM, 230/460 V,3 PH., 60HZ, TEFC, FACE-MOUNTED (56C)
- SEE NOTE 5

*AUTOMATIC FILL OPTION:

- F1 - GRAVITY SUPPLY
 - F2 - PRESSURIZED SUPPLY
 - F3 - OIL LEVEL CONTROL
 - F4 - PRESSURIZED SUPPLY WITH LEVEL CONTROL
- MOUNTS IN A PUMP STATION (SEE NOTE 2)

*LOW LEVEL OPTION:

- L1 - LOW LEVEL SWITCH HAZARDOUS AREA, CL1, GROUP C&D, CL2 GROUP E,F,G (MOUNTS IN A PUMP STATION, SEE NOTE 2)
- L2 - LOW LEVEL, 10 WATTS AT 120 VAC, SPST REED SWITCH, NC

*SHAFT ROTATION AND LOW LEVEL ALARM OPTION:

- S1 - ALARM WITH NO ELECTRICAL SWITCH
 - S2 - ALARM WITH SPDT SWITCH, HAZARDOUS AREA, CL1, GROUP B,C,D, CL2 GROUP E, F, G
 - S3 - ALARM WITH DPDT SWITCH, HAZARDOUS AREA, CL1, GROUP B,C,D, CL2 GROUP E, F, G
- MOUNTS IN A PUMP STATION (SEE NOTE 2)

*HEATER OPTION:

- H1 - ELECTRIC HEATER, HAZARDOUS AREA, CLASS 1, GROUP D (4, 6, 8 AND 12 PINT RESERVOIRS, 1 HEATER)
- H2 - ELECTRIC HEATER, HAZARDOUS AREA, CLASS 1, GROUP D (16 AND 24 PINT RESERVOIR, 2 HEATERS)
- H3 - ELECTRIC HEATER, HAZARDOUS AREA, CLASS 1, GROUP B (4, 6, 8 AND 12 PINT RESERVOIRS, 1 HEATER)
- H4 - ELECTRIC HEATER, HAZARDOUS AREA, CLASS 1, GROUP B (16 AND 24 PINT RESERVOIRS, 2 HEATERS)
- H5 - ELECTRIC HEATER, HAZARDOUS AREA, CLASS 1, GROUP D (32 AND 40 PINT RESERVOIRS, 3 HEATERS)
- H6 - ELECTRIC HEATER, HAZARDOUS AREA, CLASS 1, GROUP B (32 AND 40 PINT RESERVOIRS, 3 HEATERS)

*OMIT IF NOT REQUIRED

- NOTES:**
- When pump quantity is less than maximum pump stations of specified reservoir, blank cover assembly (Part No. 471-609-054) is placed in the unused pump stations.
 - When shaft rotation alarm, low level or automatic fill (F1 or F2) options are specified, deduct one pump station for each option.
 - Require mounting base options P6, P7, and P8.
 - May be used only with options G06 through G09 when drive option is specified.
 - M7 and M8 are foot-mounted (56F) for T1 through T5 and face-mounted (56C) for T6, T7, and T8.
 - Used only for drive options G14 through G18.

ISO 9000:2000
REGISTERED FIRM

ISO 14001
REGISTERED FIRM

© Registered trademark of LUBRIQUIP, INC.,
A Unit of IDEX Corporation, Printed in U.S.A.