

## DESCRIPTION

Manzel Model 25 Force Feed Lubricators are economical, general-purpose units of double plunger design for precise metering of lubricants (either mineral oil base or synthetics). They provide lubrication to cylinder walls, bearings and other moving parts of equipment such as sugar mills, steam engines, presses and general machinery. They are furnished with Clear-Vue Pumping Units whose sight feeds, operating at atmospheric pressure, show the output of lubricant to individual points of lubrication. All working parts are totally enclosed—away from dust, water and impurities—and self-lubricated at all times by the lubricant in the reservoir. Standard Lubricators may be had in 1 to 20 feeds for feeding the same type of lubricant. A choice of Drives and Mounting Arrangements facilitates designing Lubricators into Original Equipment or installation on existing machinery. These can be driven from rotating or reciprocating parts of machines or engines or by independent motors.

## FEATURES/BENEFITS

- GENERAL-PURPOSE LUBRICATION—automatic, precision metering for all types of machinery.
- PRESSURES—up to 1,000 psi.
- TYPE PUMPING UNIT—Clear-Vue. Sight Feed Chamber functions at atmospheric pressure. Shows amount of lubricant being pumped. Unitized construction—contains complete feed regulating mechanism. Equipped with inlet strainer.
- NUMBER OF FEEDS—1 to 20 per Lubricator, standard.
- DISPLACEMENT, OUTPUT—1/4 to 12 drops per stroke with 5/16" plunger; 1/6 to 6 drops per stroke with 3/16" plunger.
- AVAILABLE DRIVES—Direct Rotary (1:1), Ratchet, 37.5:1 and 75:1 internal gear reductions.
- RESERVOIRS—single compartment, sheet metal construction.
- FEED REGULATOR—external screw-type precisely adjustable while idle or in operation.
- REMOVABLE PUMPING UNIT—self contained. All units interchangeable—remove two pump screws and lift out.
- HAND CRANK—standard. Convenient for rapid priming of lines before start-up or for momentarily increasing supply of lubricant. Does not affect adjustment or individual pumping units. Replaces obsolete Kipp Model 50 Box Lubricators.

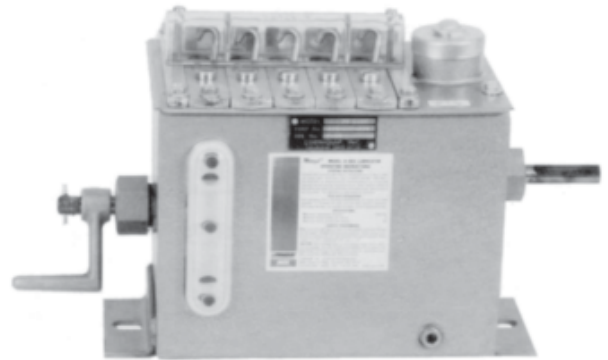

## SPECIFICATIONS

RESERVOIR—heavy-gauge fabricated sheet steel.  
CYLINDER—cast iron.  
PLUNGER—416 hardened SS, precision-ground.  
VALVE—hardened stainless steel balls  
ECCENTRICS—sintered metal, single throw on hexagon eccentric shaft.  
GASKETS, SEALS—standard for mineral oil base lubricants. Special materials available for synthetics.  
FILLER CUP—round with vents and strainer.  
DISCHARGE CHECK VALVE—Double ball discharge check valve assembly with 1/4" NPSF vertical outlet.  
FINISH—all ferrous metal drive parts Parco-Lubrited. Exterior of reservoir, cover and pumps painted with durable hammertone gray finish. Nickel plate, available.

**ASSEMBLY**

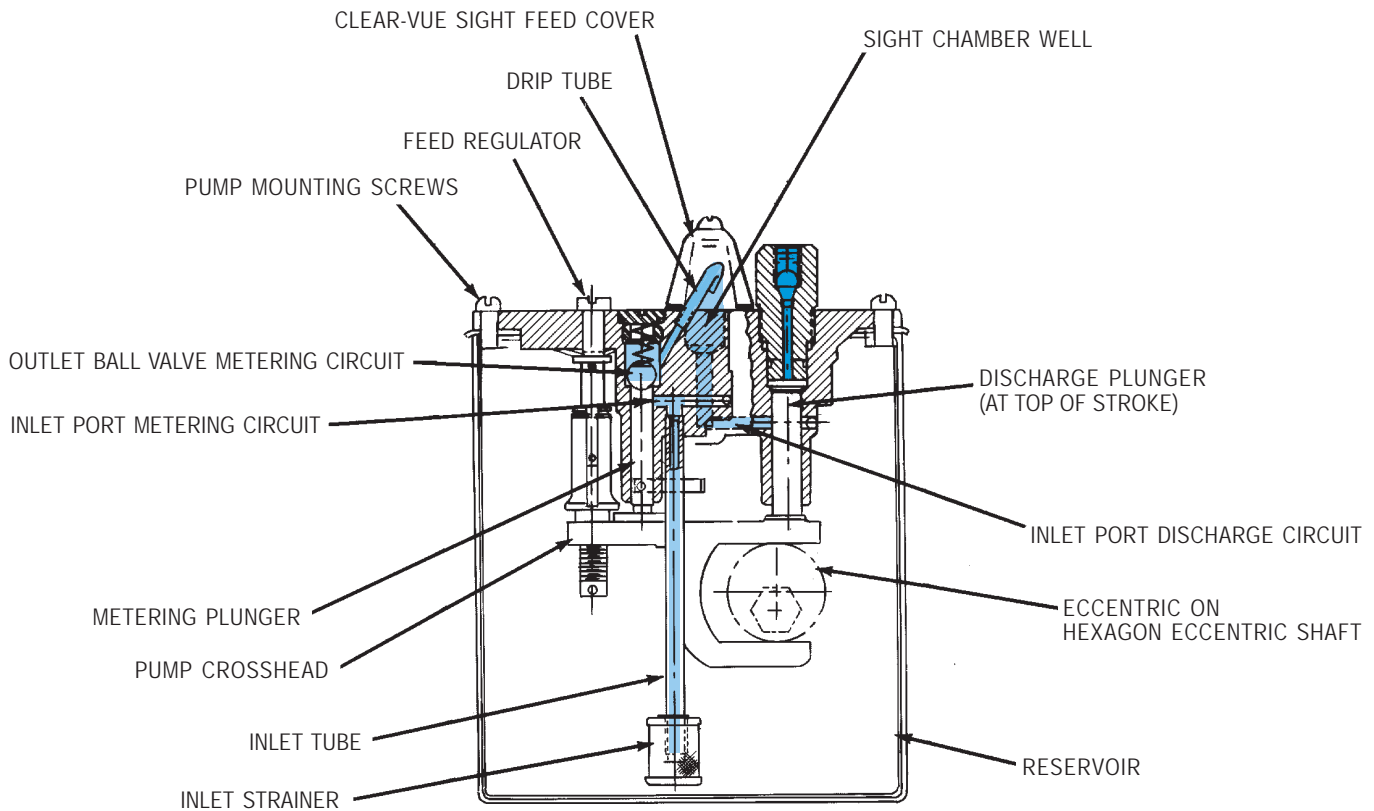

**OPERATION**

**CLEAR-VUE PUMPING UNIT**—Model 25 Lubricators operate on a double plunger pump principle with a metering and a discharge plunger actuated through a yoke by an eccentric on the eccentric shaft. The metering plunger controls the amount of lubricant fed to the discharge plunger. This metered amount is adjusted by means of an external Feed Regulator Screw, which adjusts the stroke length. The lowermost position of the plunger is varied by the Feed Regulator Screw, however the uppermost position to which the plunger rises remains constant.

On the downstroke, the metering plunger draws lubricant up through the inlet tube, over the inlet valves and into the metering pump cylinder. On the upstroke, the metering plunger seats its inlet valves and opens its spring-loaded outlet valve forcing the metered amount of lubricant, at low pressure, out the drip tube into the Sight Chamber Well at atmospheric pressure. On the same downstroke, the discharge plunger opens the cross port

to the Well and draws the metered amount of lubricant into the discharge pump cylinder. This path is shown in light blue on the Assembly Drawing.

Finally, on the upstroke, the discharge plunger closes the cross port from the Sight Well and forces the metered amounts of lubricant over the discharge valves and into the line, as shown in solid blue on the Assembly Drawing.

**CLEAR-VUE**

Sight Feed Chamber contains no “sight feed fluid” and functions at atmospheric pressure. Molded glass sight cover and dust shield in various lengths for 1 to 8 pumping units. Drip tube for each line indicates amount of lubricant fed each point of lubrication.

**NOTE:** Due to design characteristics, the Model 25 pump can only be used in pump to point system. Components such as flow sensors and divider valves should not be used. Only check valves are permitted between the pump and the lube point.

## OPERATING INSTRUCTIONS

### LUBRICATOR INSTALLATION AND OPERATION

The Manzel Model 25 Lubricator consists of a metal reservoir which contains the drive mechanism, ratchet or rotary, the individual pump units and accessory equipment as ordered.

The Lubricator should be solidly mounted and aligned to connect the drive shaft to the proper stroking or rotary motion. This drive motion, through the Lubricator drive, should operate the Lubricator eccentric and hand crank shaft between 3 and 60 RPM. There is one pump stroke for every revolution of the hand crank shaft, which is an extension of the eccentric shaft. The proper eccentric shaft RPM should be determined from the required maximum and minimum pump feed rates. The RPM selected should be such that, when each pump is set at its required feed rate, the feed rate can still be increased or decreased by the feed regulator screw. In most cases, due to the wide adjustment of the pump units, there will be considerable allowance in the selection of the proper eccentric shaft speed. **Note:** this eccentric shaft speed will seldom be the same as the Input shaft speed, but will always be the same speed as the hand crank shaft extension.

The individual pumps operate on a double plunger principle with the metering and discharge plungers actuated through a yoke or crosshead by an eccentric on the eccentric shaft. The small or metering plunger draws a metered amount of oil from the reservoir over the inlet ball valves and forces it over the outlet ball valve through the drip tube and into the clear-vue sight well at atmospheric pressure. The discharge plunger draws the metered amount of oil along with air from the sight well over the inlet sleeve valve and forces this mixture over the ball discharge valves toward the point of lubrication. The stroke of the small metering plunger is varied to change the metered oil intake by means of the external feed regulator screw. The stroke of the discharge plunger is constant.

### IMPORTANT—KEEP LUBRICATOR CLEAN

First, use only new or filtered lubricant. Periodic cleaning of the Lubricator is recommended, since lubricant is subject to fouling from atmospheric dusts and additives. To do this, remove all pumping units; clean them and the reservoir by dipping and brushing in a cleaning solvent. Clean all lubrication tubing and check valves thoroughly at the same time. Next, recharge Lubricator and bleed lubrication lines at terminal check valve to assure full lubrication before putting equipment back into operation.

### STARTING INSTRUCTIONS

Fill Lubricator reservoir with new or filtered lubricant to top of reservoir gauge glass. For initial start-up, adjust pump for maximum delivery by turning feed regulator as indicated by directional arrow. Then, operate pumps at this setting and bleed lubrication lines at terminal check valve to assure full lubrication. The Lubricator is now ready for operation.

### FEED RATE REGULATION

Each pumping unit is regulated independently by means of a feed regulator. To decrease the feed, turn the feed regulator clockwise. To increase the feed, turn counter-clockwise. (Follow directional arrow.)

### HAND CRANK OPERATION

The hand crank on the end of the Lubricator is for use before starting or for momentarily increasing lubricant supply while the Lubricator is in operation. It operates all feeds at once, but does not affect feed regulation.

### PUMP REMOVAL AND REPLACEMENT

To remove a pump, stop the Lubricator. Remove the discharge line connection and the pump mounting screws. Next, loosen the adjacent pump mounting screws. Lift out front end of pump (end with feed regulator screw) pulling it forward and upward at the same time. This will allow the yoke or crosshead to clear the eccentric and the pump can be lifted out. Before replacing a pump, position yoke down as far as possible and then reverse the above procedure.

### TROUBLESHOOTING OVERFLOWING SIGHTWELL

If the pump sight well fills and overflows into adjacent sight wells, the cause is dirty or inoperative pump discharge valves. To correct:

1. Flush discharge check valves.
  - a. Turn feed regulator to full open.
  - b. Operate hand crank rapidly.
2. Remove discharge check valves if condition still exists.
  - a. Shut down unit or turn feed regulator to full closed.
  - b. Remove discharge line connections.
  - c. Remove outlet connection from pump unit.
  - d. Remove check valve. Clean and reseal, if necessary, (care must be exercised to prevent marking the bottom surfaces when reseating) or replace as conditions require.
  - f. Check top and bottom surfaces of the check valve. These must be free from radial nicks and scratches, as these surfaces seal against the discharge pressure. Any leakage around the threads of the outlet connection can be traced back to dirty or marked check valve cage, outlet connection, or cylinder sealing surfaces.
  - g. Install check in pump housing. Make sure the ball and spring side of the cage faces up.
  - h. Replace outlet connection.
  - i. Replace discharge line connection and put pump back in operation.

### ERRATIC PERFORMANCE

Make sure the sight glass is open to atmospheric pressure through the felt gasket between the glass and reservoir. These pumps must be able to bring air into the sight chamber through this gasket. Make certain it is not contaminated with paint or dirt.

### GAUGE GLASS LEAKAGE

Drain Lubricator, check for leaks, and replace level sight/gasket if necessary.

### SYNTHETIC LUBRICANTS

In general, the use of synthetic lubricants will require that the standard neoprene and Buna N gaskets and seals for petroleum base lubricants be replaced with Butyl rubber gaskets and seals. Refer to Parts List for the part numbers of the gaskets for use with synthetic lubricants.

MODEL 25 PUMP SPECIFICATIONS

NO. OF FIELDS ☑	PLUNGER	PUMP-ING UNITS	PUMPING UNIT CHARACTERISTICS ①											LUBRICANTS MINERAL OILS AND SYNTHETICS ②
			OPERATIONAL											
RANGE: 1-MAX.	NOMINAL DIAMETER (Inches)	TYPES AVAILABLE (See Legend Above)	MAX. OPERATING PRESSURE-PSI	DROPS/STROKE	CU. IN./STROKE	C.C./STROKE	DROPS/PINT	DROPS/CU. IN.	DROPS/C.C.	STROKES/MIN.	VISCOSITY (SSU @ 100°F) ③			
20	5/16	⊙	1000	12 MAX. 1/4 MIN.	.0245 MAX. .0005 MIN.	.399 MAX. .008 MIN.	14.115	490	30	60 MAX. 3 MIN.	5000 MAX.	80 MIN.		
	3/16	⊙	1000	6 MAX. 1/6 MIN.	.0122 MAX. .0003 MIN.	.199 MAX. .005 MIN.	14.115	490	30	60 MAX. 3 MIN.				

- ☑ Standard maximums regularly in production. Where additional feeds are required, contact factory.
- ① All displacements based on SAE30 Oil (SSU @ 100°F) at room temperature.
- ▲ The capacities of reservoirs are originally determined by the number of feeds. Larger ones available on request.
- ⊙ Special sight glass and gasket materials required. All surfaces in contact with lubricant must be free of paint.
- ③ Approximate Viscosities--SAE 10=200 SSU @ 100°F; 600W=2000 SSU @ 100°F
- ★ Manzel Lube Line Alert or Lube Sentry should not be used with the Model 25 Box Lubricator. Contact factory for complete details.

DRIVES

**DIRECT ROTARY**-(1:1) Shaft located either or both ends.

**STANDARD RATCHET**-(See Graph for drive ratio per degree stroke.) Two variations available: (a) Shaft located either end. The drive reduction ratio depends on the degree stroke taken on the input shaft from a minimum of 13° for a 37-1/2:1 ratio to a maximum of 90° for a 4-1/6:1 ratio. (b) Shaft located front or rear. The drive ratio depends on the degree stroke taken on the input shaft from a minimum of 13° for a 37-1/2:1 ratio to a maximum of 38° for a 9.4:1 ratio.

**REDUCED ROTARY DRIVES**-37.5: 1 or 75: 1 internal geared reducers. Available in right or left hand end drive configurations with primer hand on opposite end to drives.

CHART: DRIVE RATIO PER DEGREE STROKE

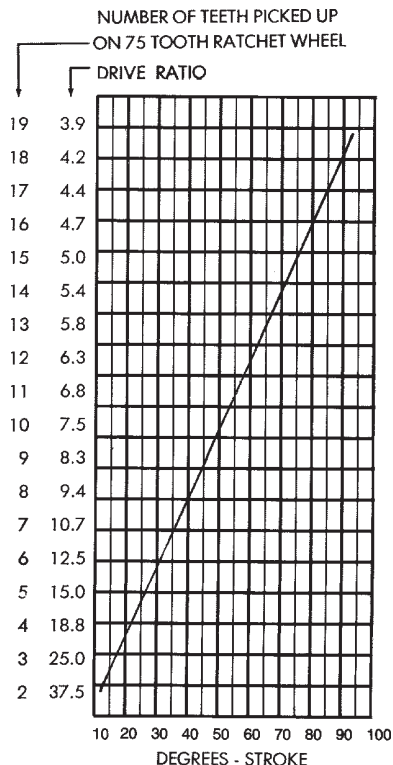

**DIMENSIONS**

To establish installation requirements, determine the desired number of feeds, the corresponding reservoir length, the capacity, the center-to-center distance of mounting holes, and the drive shaft location.

NUMBER OF FEEDS	RESERVOIR LENGTH A	C. TO C. OF END LUGS B	APPROX. CAPACITY PINTS
1 - 4	7-19/32"	8-27/32"	6-1/4
5 - 8	11-19/32"	12-27/32"	9-1/4
9 - 12	16-19/32"	17-27/32"	13
13 - 16	20-19/32"	21-27/32"	16
17 - 20	25-19/32"	26-27/32"	19-3/4

\* Table makes dimensional allowance of 1" for each Center Bearing, evenly spaced between pumping unit groups of 8.

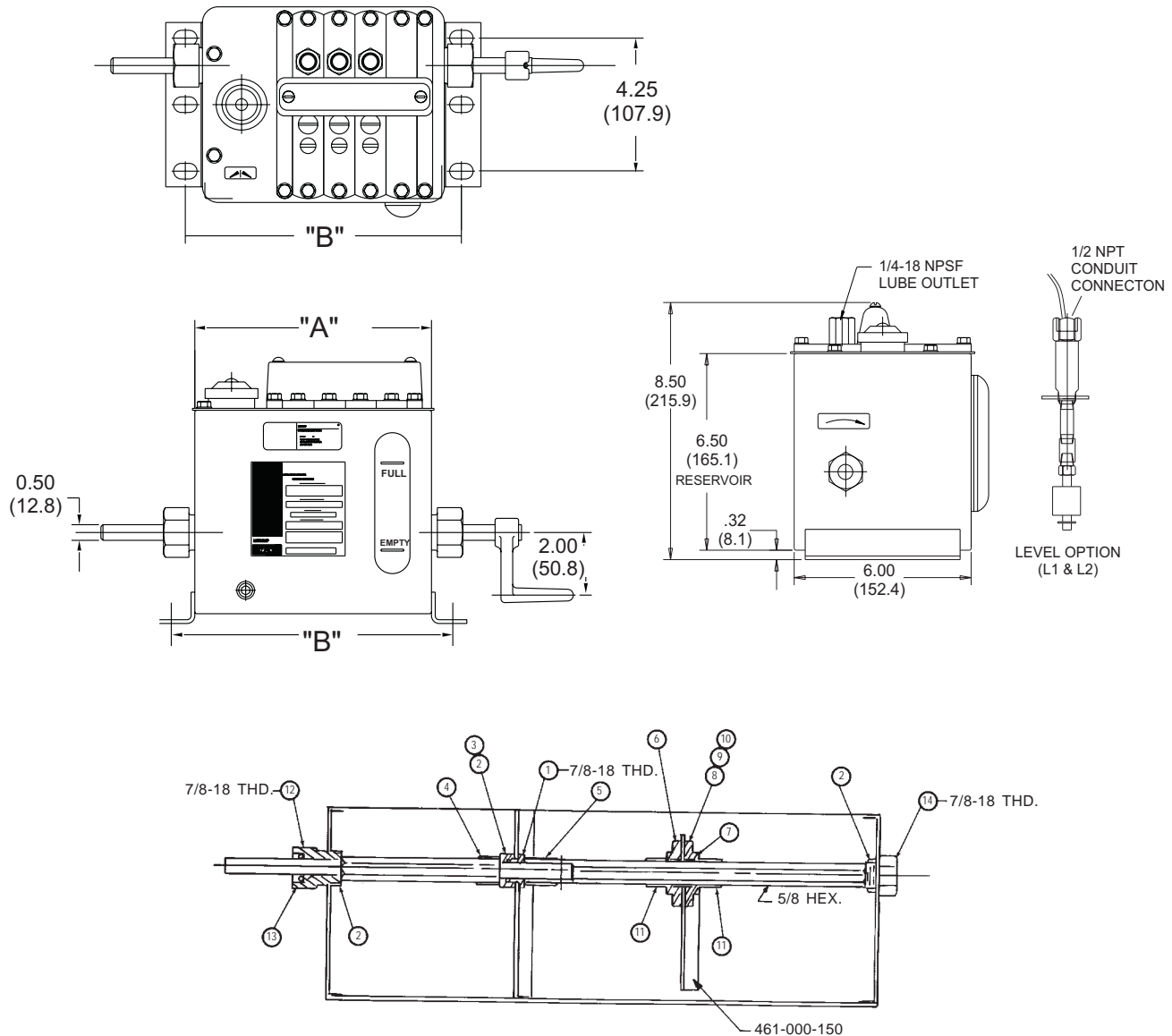

**SEALED COMPT. OPTION**

- 1) 402-080-020-BRG.
- 2) 410-700-050-NUT
- 3) 439-079-230-PACKING
- 4) 424-050-180-SPACER
- 5) 424-050-200-SPACER ASSY.

**BRG. SUPPORT OPTION**

- 6) 402-060-000-BRG.
- 7) 402-060-010-BUSHING
- 8) 402-060-070-BRG.
- 9) 415-020-020-SCR.
- 10) 421-060-080-L'WASHER
- 11) 424-050-180-SPACER

**END BRG**

- 12) 402-040-000-BRG.
- 13) 423-010-180-OIL SEAL
- 14) 402-000-040-BRG.

MODEL 25 BOX LUBRICATOR  
PART NUMBER CONVERSION CHART

OLD PART NUMBER	NEW PART NUMBER	DESCRIPTION	OLD PART NUMBER	NEW PART NUMBER	DESCRIPTION
60050-B	321-410-015	5/16" DIA. COMPLETE PUMP	1948-5	439-071-060	GSKT-SIGHT FEED TO MATCH 1949-5 (438-028-110)
60050-S4B	321-210-015	3/16" DIA. COMPLETE PUMP	1948-6	439-071-070	GSKT-SIGHT FEED TO MATCH 1949-6 (438-028-120)
6056-B	428-165-021	FRICITION PLUG SPRING ASSEMBLY	1948-7	439-071-080	GSKT-SIGHT FEED TO MATCH 1949-7 (438-028-130)
6061-B	463-920-580	DISCHARGE VALVE ASSEMBLY (CAGE)	1948-8	439-071-090	GSKT-SIGHT FEED TO MATCH 1949-8 (438-028-140)
6064	418-700-240	REGULATING FORK RING	1949-1	438-028-070	SIGHT FEED GLASS
6065	453-030-010	REGULATING FORK SCREW	1949-2	438-028-080	SIGHT FEED GLASS
6066	435-030-020	REGULATING STEM	1949-3	438-028-090	SIGHT FEED GLASS
6067	421-700-230	REGULATING STEM WASHER	1949-4	438-028-100	SIGHT FEED GLASS
6068	458-165-030	REGULATING STEM SPRING	1949-5	438-028-110	SIGHT FEED GLASS
6075	480-000-180	VERTICAL OUTLET 1/8" NPTF	1949-6	438-028-120	SIGHT FEED GLASS
6401	458-005-310	SPRING - OUTLET VALVE	1949-7	438-028-130	SIGHT FEED GLASS
60051	437-700-400	CYLINDER PLUG	1949-8	438-028-140	SIGHT FEED GLASS
60052	439-075-190	CYLINDER PLUG WASHER	6001	---	RESERVOIR ) ITEMS DEPEND UPON
60058-S1B	463-920-091	SUCTION VALVE ASSEMBLY	6003	---	COVER ) LENGTH OF RESERVOIR
82-1086-8	473-020-091	STRAINER	6200	---	ECCENTRIC SHAFT) AND NUMBER OF
1X13	410-010-030	3/16" DIA. BALL	6204	---	ECCENTRIC SHAFT) FEEDS
1X16	401-010-060	9/32" DIA. BALL	6079	461-000-110	SIGHT GLASS FASTENING STRIP
60058-S1B	433-700-520	DRIP TUBE	6080	461-000-130	PUMP BLANK OFF PLATE
1X19	401-010-090	3/8" DIA. BALL - OUTLET VALVE	6080-S1	461-000-140	CENTER SIGHT GLASS FASTENING STRIP
11X340	411-030-400	GROOVE PIN REGULATING FORK	6081-B	438-028-171	GAUGE GLASS ASSEMBLY
82-1017	435-090-040	FLARELESS 1/8-NPTF 1/4" OD STR. CONN.	6081	438-028-020	GAUGE GLASS
82-1017-S1	435-090-070	FLARELESS 1/8-NPTF 5/16" OD STR. CONN.	530-S1	437-700-030	PLUG
82-1017-S2	435-090-030	FLARELESS 1/8-NPTF 3/16" OD STR. CONN.	2144	437-700-100	CAP PLUG
82-1017-S3	435-090-090	FLARELESS 1/8-NPTF 3/8" OD STR. CONN.	2234	439-060-020	WASHER
82-1018	435-130-040	FLARELESS 1/8-NPTF 1/4" OD ELBOW CONN.	2349-S1	484-040-000	WASHER GUIDE
82-1018-S1	435-130-060	FLARELESS 1/8-NPTF 5/16" OD ELBOW CONN.	6081-S1B	438-028-181	GAUGE GLASS ASSY. FOR SYNTHETICS
82-1018-S2	435-130-030	FLARELESS 1/8-NPTF 3/16" OD ELBOW CONN.	2234-S2	439-060-050	WASHER FOR SYNTHETICS
82-1018-S3	435-130-080	FLARELESS 1/8-NPTF 3/8" OD ELBOW CONN.	6083-B	473-040-091	FILLING CUP & COVER ASSY. (OBSOLETE)
1226-S5B	402-040-271	OIL SEAL BEARING ASSEMBLY	6083	---	FILLING CUP
1226-S5	402-040-000	OIL SEAL BEARING	6084	471-680-020	FILLING CUP COVER
23X110	423-010-210	OIL SEAL	6086	411-700-100	FILLING CUP PIN
1229	410-700-040	JAM NUT	6087-B	473-020-061	FILLING CUP STRAINER - 1-3/4" DEEP
1226-S12B	---	OIL SEAL BEARING ASSY. FOR SYNTHETICS	2898-B	473-020-041	FILLING CUP STRAINER - 3/4" DEEP
23X118	423-010-180	OIL SEAL (SYNTHETIC USE)	6092-S2B	426-011-191	HAND CRANK ASSEMBLY
1705	454-006-000	ECCENTRIC	6092-S2	426-011-010	HANDLE
1864	402-080-020	BEARING	3064	458-005-300	SPRING
1865	410-700-050	NUT	11X344	411-030-440	GROOVE PIN
CH-110-S1	439-079-230	PACKING	6093	424-050-150	SPACER BETWEEN FEEDS
CH-110-S2	439-079-040	PACKING	6094	---	SPACER ENDS
1948-1	439-071-020	GSKT-SIGHT FEED TO MATCH 1949-1 (438-028-070)	6094-3	424-050-190	SPACER BETWEEN CENTER BRG. & FEEDS
1948-2	439-071-030	GSKT-SIGHT FEED TO MATCH 1949-2 (438-028-080)	6090	415-640-040	PUMP FASTENING SCREW
1948-3	439-071-040	GSKT-SIGHT FEED TO MATCH 1949-3 (438-028-090)	6097-B	402-060-070	CENTER BEARING ASSEMBLY
1948-4	439-071-050	GSKT-SIGHT FEED TO MATCH 1949-4 (438-028-100)	6414	---	RES. COVER GSKT-SIZE BASED ON LENGTH OF RES.

MODEL 25 BOX LUBRICATOR  
PART NUMBER CONVERSION CHART (CONTINUED)

OLD PART NUMBER	NEW PART NUMBER	DESCRIPTION	OLD PART NUMBER	NEW PART NUMBER	DESCRIPTION
77-634	439-075-170	WASHER-SIGHT FEED GLASS	28X11	439-071-000	FELT SLUG - 1/2 OD x 5/16" LG.
13X114	412-130-140	DRAIN PLUG-1/4" NPTF	1879-S5	459-158-070	RATCHET WHEEL - 75 TEETH
16X4703	416-470-030	SCREW - COVER 10-32 X 5/16" LG. ROUND HEAD	6103-B	---	BRAKE ASSEMBLY
16X4706	416-470-060	SCR.-SIGHT GL. FASTN. STRIP 10-32 x 1/2" RND.	1886	---	BRAKE PAWL
16X4713	416-470-130	SCR.-SIGHT FEED GLASS 10-32 x 1-1/2" RND. HD.	6101	---	TORSION SPRING
16X5123	416-501-230	SCR.-PUMP 1/4-28 x 3/4" LG. FILLISTER HD.	6102	411-700-701	TORSION SPRING
1229	410-700-040	JAM NUT	6103	400-295-200	BRAKE
1725	402-000-040	BEARING	6105	415-700-050	PAWL PIN BOLT
1879-S5	459-158-070	RATCHET - 75 TEETH	6106-BLH	453-004-151	ROCKER ARM ASSEMBLY
6103-BRH	453-000-021	BRAKE ASSEMBLY	6106-BRH	453-004-161	ROCKER ARM ASSEMBLY
6103-BLH	453-000-031	BRAKE ASSEMBLY	6102-S2	411-700-520	SPRING PIN
6107-S2C	453-020-150	ROCKER ARM ASSEMBLY	6106	453-004-140	ROCKER ARM
1259-S1	415-700-050	PAWL PIN	16X1143	416-110-430	SCREW 5/16-18 x 1-1/2" FILLISTER HD.
1886	459-218-010	PAWL	21X12	421-010-020	LOCKER WASHER 5/16"
6101	458-185-020	TORSION SPRING	6118	465-001-830	RATCHET SHAFT
6102-S5	411-700-120	SPRING PIN	9X19	409-010-090	No. 3 WOODRUFF KEY
6107-S2C	453-020-150	ROCKER ARM	1204-B	453-004-111	ROCKER ARM ASSEMBLY
6107-S2B	453-020-031	ROCKER ARM	1204	480-000-020	OUTSIDE ROCKER ARM
10X22	410-020-020	PAWL PIN NUT 5/16-18	1203-B	480-000-031	ADJUSTABLE CONNECTION ASSY.
6108	402-020-050	BEARING	1202	480-000-000	ENGINE CONNECTION
6119-B	465-020-061	DRIVE SHAFT ASSY. FOR 37-1/2:1 RATIO	1203	480-000-010	ADJUSTABLE CONNECTION
6116	454-006-020	CAM	1243	415-700-000	PIN
6119	---	SHAFT - DEPENDS ON LENGTH	15X4903	415-490-030	SET SCREW 5/16-18 X 1/2" CUP POINT
11X429	411-040-290	GROOVE PIN	6070	473-020-091	STRAINER ASSY.
6119-S32B	465-020-321	DRIVE SHAFT ASSY. FOR 25:1 RATIO	87-1	453-004-000	3/8" ROD 6" LG.
6116-S3	454-006-180	CAM	15X35	415-030-050	CAP SCREW 3/8-16 x 1" LG.
6119-S2B	465-002-010	DRIVE SHAFT ASSY. FOR 18-3/4:1 RATIO	15X4902	415-490-020	SET SCREW 5/16-18 x 5/8" LG. CUP POINT
6116-S1	454-006-150	CAM	405-010-020		DRAIN COCK
6119S18B	465-020-051	(OBSOLETE)	453-020-150		INSIDE RATCHET ARM )
6120	421-700-250	SPACER - DRIVE SHAFT	454-000-240		CAM )
15X21	415-020-010	CAP SCREW - 5/16-18 x 1/2" LG.	465-020-071		DRIVE SHAFT ) LONG STROKE RATCHET
			439-071-000		WASHER )
			453-004-140		ROCKER ARM

**ORDERING INFORMATION**

M25 - XX - XX - XX - XX - X - XX

**Reservoir**

- R1 - 1-4 Pump Station Reservoir
- R2 - 5-8 Pump Station Reservoir
- R3 - 9-12 Pump Station Reservoir
- R4 - 13-16 Pump Station Reservoir
- R5 - 17-20 Pump Station Reservoir

**Pump Size**

- P0 - No Pump
- P1 - 3/16" Dia. Plunger, 1,000 PSI Maximum Operating Pressure
- P2 - 5/16" Dia. Plunger, 1,000 PSI Maximum Operating Pressure

**Pump Quantity**

- 0 - 20 Pumps

**Drive Options**

- D1 - Direct Rotary (1:1)
- D2 - Standard Ratchet (Less Ratchet Arm)
- D3 - 37.5:1 Ratio
- D4 - 75:1 Ratio

**Drive Locations**

- L - Left Hand End
- R - Right Hand End

**Level Options**

- L0 - None
  - L1 - Low Level Switch (SPST Reed Type), 10W @ 115VAC
  - L2 - High Level Switch (SPST Reed Type), 10W @ 115VAC
- } Requires 1 Pump Station per Switch

**NOTE:** Additional Model 25 Lubricators may be available upon request. Please supply serial number, complete application information and number of units required when requesting quotation.

**Model 25 Components & Accessories**

Description	Part Number
3/16" Replacement Pump .....	321-210-015
5/16" Replacement Pump .....	321-410-015
Ratchet Arm Assembly .....	453-004-111

**Model 25 Dome Sight Glasses (requires gasket sold separately)**

NUMBER OF FEEDS	SIGHT GLASS PART NUMBER	GASKET PART NUMBER
1	438-028-070	439-071-020
2	438-028-080	439-071-030
3	438-028-090	439-071-040
4	438-028-100	439-071-050
5	438-028-110	439-071-060
6	438-028-120	439-071-070
7	438-028-130	439-071-080
8	438-028-140	439-071-090

ISO 9000:2000  
REGISTERED FIRM

ISO 14000  
REGISTERED FIRM

© Registered trademark of LUBRIQUIP, INC.,  
A Unit of IDEX Corporation, Printed in U.S.A.